



# Chandigarh Judicial Academy

Sector 43-D, Chandigarh – 160022

Phone No. 0172-6662156 Fax No. 0172-6662178

Website: [www.cja.gov.in](http://www.cja.gov.in) email id: [cja.chd@hotmail.com](mailto:cja.chd@hotmail.com)

No: Dir/CJA/2021/2094

Dated: 7<sup>th</sup> December, 2021

## NOTICE FOR QUOTATION.

Chandigarh Judicial Academy invites quotations for purchase of items detailed below in the name of 'THE DIRECTOR (ADMINISTRATION), CHANDIGARH JUDICIAL ACADEMY till 23<sup>rd</sup> December, 2021 upto 5:00 PM:-

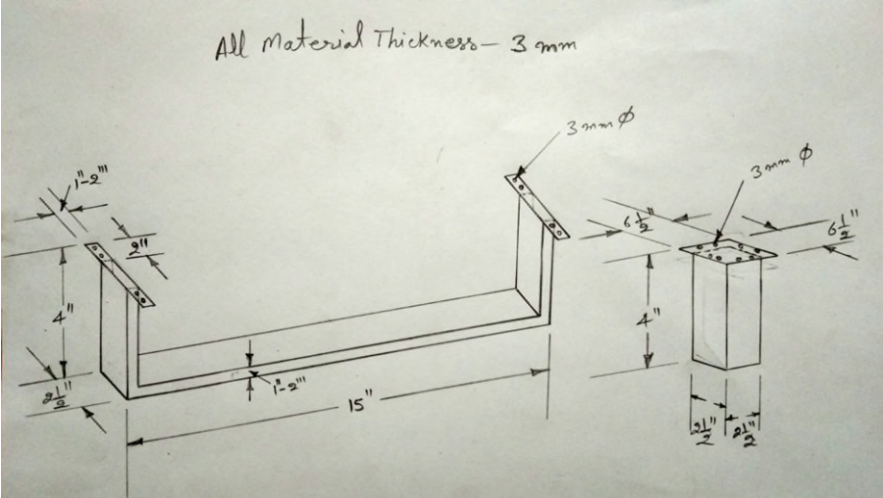
Sr. No.	Description of item	A/U	Quantity
<b>HARDWARE MATERIAL</b>			
1.	Hinges Brass 3" x 3/4" x 1/2"	Nos.	12
2.	L- Hinges Brass 3" x 19mm	Nos	08
3.	Brass Screw 3/4"	Nos	140
4.	Magnetic Push to open Latch 3" Ebco/Hettich/Hafele)	Nos	10
5.	Drawer Telescopic Channel (Push to Open) 14" (Ebco/Hettich/Hafele)	Set	03
6.	Plastic Buffer 1"	Nos	14
7.	Nail 2"	Kg	1
8.	Nails 1 1/2 "	Kg	1
9.	Nails 19 No. – Head Less 3/4"	Gms	250
10.	Nail 1" – 17 No. with Head	Kg	1/2
<b>BOARD/PLY BOARD MATERIAL</b>			
1.	Board 8'x4'x19mm (Century/Club Prime BWP)	Nos.	09
2.	Board 8'x4'x 6mm (Century/Club Prime BWP)	Nos	01
<b>TIMBER ITEMS</b>			
1.	MP Teak Wood 2"-2" x 1"-2" x 3' (with plaining)	Pcs	20
2.	MP Teak Wood 1"-2" x 5" x 3' (with plaining)	Pcs	65
<b>STEEL ITEMS</b>			
1.	Steel Strip 14" x 1" x 1/2" Matte Finish (As per sample/photo)	Nos	10
			
2.	Steel Leg 15" x 4" x 2 1/2" Matte Finish (As per sample/photo) Material used thickness – 3mm	Nos	02
			



# Chandigarh Judicial Academy

Sector 43-D, Chandigarh – 160022

Phone No. 0172-6662156 Fax No. 0172-6662178

Website: [www.cja.gov.in](http://www.cja.gov.in) email id: [cja.chd@hotmail.com](mailto:cja.chd@hotmail.com)

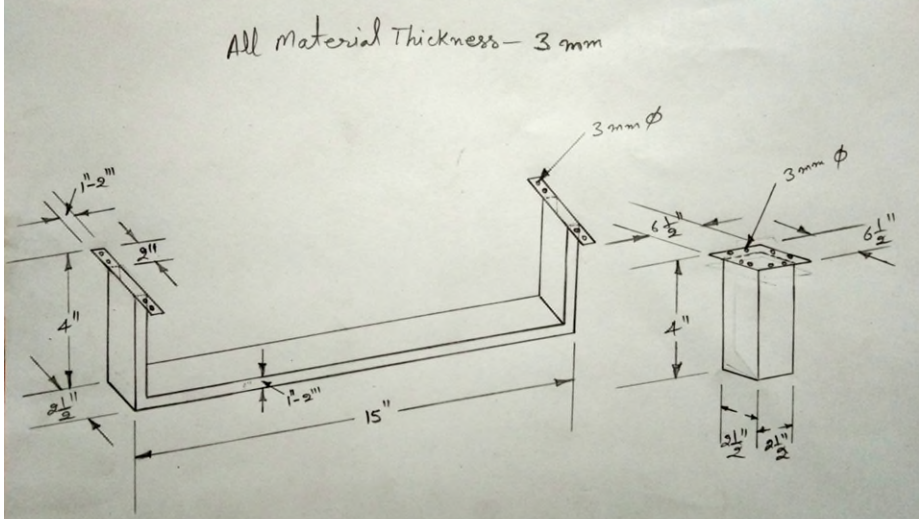
3.	Steel Leg 2 ½" x 2 ½" x 4" Matte Finish (As per sample/photo) Material used thickness – 3mm	Nos	01
			

Sealed quotations should be superscribed with:- “**QUOTATION FOR items related to the trade of carpenter**”

Quotation may also be tendered via official email of the Academy i.e. [admn@cja.gov.in](mailto:admn@cja.gov.in) by way of scanning the quotes on the letter heads of the respective dealers/firms or by hand/post. Quotations received after due date will not be considered and Academy shall not be responsible for any postal delay.

--sd--

Director (Administration)  
Chandigarh Judicial

Academy

## Terms & Conditions:

1. Offered rates should clearly indicate Base price/Cost, GST, F.O.R. charges or any other charges applicable.
2. Bid shall be allotted by issuance of supply order
3. Payment will be made only after completion of work in all respect and request for advance payment (part or full shall not be entertained)
4. Addendum/Corrigendum if required will only be uploaded on the website of Chandigarh Judicial Academy



# Chandigarh Judicial Academy

Sector 43-D, Chandigarh – 160022

Phone No. 0172-6662156 Fax No. 0172-6662178

Website: [www.cja.gov.in](http://www.cja.gov.in) email id: [cja.chd@hotmail.com](mailto:cja.chd@hotmail.com)

---

---

5. Academy reserves the right for any addition/deletion/alteration of materials/specifications before/after awarding the bid without any compensation.
6. Academy reserves the right to accept or reject any/all the offer without giving any reasons thereof.
7. Academy reserves the right to select/reject one or more Bidders. The Academy does not bind itself to accept the lowest or any tender and reserves the right to accept or reject any or all tenders either in whole or in part, without assigning any reasons whatsoever. Conditional tenders are liable to be rejected.
8. Bidders should be registered with GST
9. Guarantee/warranty of the products/repair work should be mentioned in the quotation.

Contact person for enquiries: – Sh. Gaurav Kumar (Ph. No. 0172-6662161, Sh. Sunil Kumar, M – 8289011836)